



SCREAMING PCB assembly
As fast as 24-hours
Prototype & short-run

ELECTRONICS LAB



<http://www.electronics-lab.com>

[Home](#)

[Projects](#)

[Action](#)

[Downloads](#)

[Articles](#)

[Links](#)

[Community](#)

[Contact](#)

[Faucet Light + Leds 12.79](#)
Make your Water Glow On Sale 12.79
Price Beat Policy+Other cool Gadget
www.sciencetoystore.com

[Solar LED Numbers](#)
Modern, Hi-Tech Solar LED Address
Numbers. Low Price. Order A Set Now
www.matterinc.com/solar-address

[Machine Vision Backlight](#)
High performance LED Edgelit Easy to
customize color, dimensions
www.leutron.com

[Li-Ion & NiMH Charger ICs](#)
Battery Charger ICs - Any Chemistry Free
Battery Charger Brochure!
www.linear.com

[Home](#) → [Projects](#) → [Motor, light and power control](#) → [Fading LEDs](#)

Fading LEDs

source: [RED Free Circuit Designs](#)

Two strips of LEDs fading in a complementary manner

9V Battery-operated portable unit

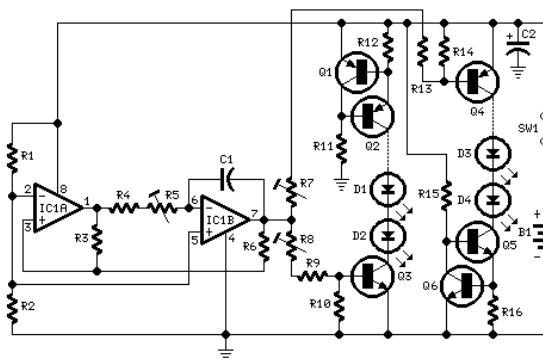

Parts:

R1, R2	4K7	1/4W Resistors
R3	22K	1/4W Resistor
R4	1M	1/4W Resistor (See Notes)
R5	2M2	1/4W Carbon Trimmer (See Notes)
R6, R10, R11, R14, R15	10K	1/4W Resistors
R7, R8	47K	1/4W Carbon Trimmers (See Notes)
R9, R13	27K	1/4W Resistors
R12, R16	56R	1/4W Resistors
C1	1 μ F	63V Polyester Capacitor
C2	100 μ F	25V Electrolytic Capacitor
D1-D4 etc.	5 or 3mm.	LEDs (any type and color) (See Notes)
IC1	LM358	Low Power Dual Op-amp
Q1, Q2, Q4	BC327	45V 800mA PNP Transistors
Q3, Q5, Q6	BC337	45V 800mA NPN Transistors
SW1	SPST	miniature Slider Switch

B1 _____ 9V PP3 Battery

Clip for PP3 Battery

Device purpose:

This circuit operates two LED strips in pulsing mode, i.e. one LED strip goes from off state, lights up gradually, then dims gradually, etc. while the other LED strip do the contrary. Each strip can be made up from 2 to 5 LEDs at 9V supply.

Circuit operation:

The two Op-Amps contained into IC1 form a triangular wave generator. The rising and falling voltage obtained at pin #7 of IC1 drives two complementary circuits formed by a 10mA constant current source (Q1, Q2 and Q5, Q6) and driver transistor (Q3 and Q6).

R4, R5 & C1 are the timing components: the total period can be varied changing their values. R7 & R8 vary the LEDs brightness.

Notes:

- For those wishing to avoid the use of trimmers, suggested values for a 9V supply are: R4=3M9, R9 & R13=47K and trimmers replaced by a short.
- Whishing to use a wall-plug transformer-supply instead of a 9V battery, you can supply the circuit at 12V, allowing the use of up to 6 LEDs per strip, or at 15V, allowing the use of up to 7 LEDs per strip.
- In this case, the value of the trimmers R7 & R8 should be changed to 100K.

Low-Cost Prototype Boards

AVR, PIC, ARM7, MSP430 Shipped from Canada www.optimal-microsystems.com

[Ads by Google](#)

[Advertise on this site](#)

[Search Site](#) | [Support us](#) | [Advertising](#) | [Profile](#) | [Books](#) | [Gadgets](#) | [Add your link here](#)
[Free Schematics Search Engine](#) | [Electronic Kits](#) | [Best Buy Mobile Phones](#) | [Pricemate](#) | [Serial LCD & LED Display](#)

Electronics-lab.com © 2002-2006

Any logo, trademark and project represented here are property of their respective owner

[Ads by Google](#)

[White LED Circuit](#)

[Circuit Project](#)

[Electronic Project](#)

[Power Supply Project](#)

[10MM LED](#)